



**Cooking Range Line thermaline 90
4 Zone Induction Top, 1 Side -
Marine USPHS only M2M**

ITEM # _____

MODEL # _____

NAME # _____

SIS # _____

AIA # _____

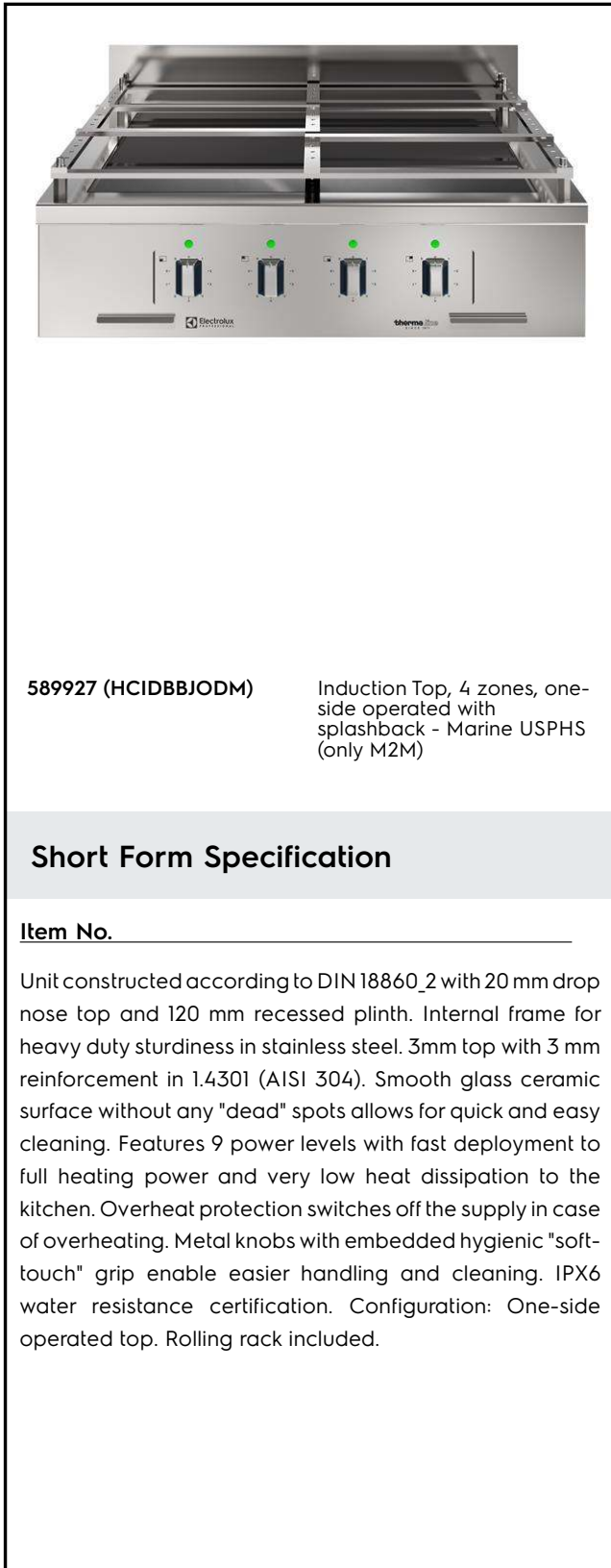

589927 (HCIDBBJODM) Induction Top, 4 zones, one-side operated with splashback - Marine USPHS (only M2M)

Short Form Specification

Item No. _____

Unit constructed according to DIN 18860_2 with 20 mm drop nose top and 120 mm recessed plinth. Internal frame for heavy duty sturdiness in stainless steel. 3mm top with 3 mm reinforcement in 1.4301 (AISI 304). Smooth glass ceramic surface without any "dead" spots allows for quick and easy cleaning. Features 9 power levels with fast deployment to full heating power and very low heat dissipation to the kitchen. Overheat protection switches off the supply in case of overheating. Metal knobs with embedded hygienic "soft-touch" grip enable easier handling and cleaning. IPX6 water resistance certification. Configuration: One-side operated top. Rolling rack included.

Main Features

- Overheat protection: the temperature sensor switches off the supply in case of overheating.
- Pans can easily be moved from one area to another without lifting.
- The smooth glass-ceramic surface can be quickly and easily cleaned, thus providing maximum hygiene.
- All major components may be easily accessed from the front.
- Metal knobs with embedded hygienic "soft-touch" grip for easier handling and cleaning. The special design of the controls prevents infiltration of liquids or soil into vital components.
- 9 power levels.
- Fast deployment with full heating power immediately.
- Low heat dissipation to the kitchen.
- IPX6 water protection.
- Can be installed on any base, also from other supplier. Bases must be designed according to the TL90 and TL85 construction guidelines.

Construction

- Control light for each zone.
- Internal frame for heavy duty sturdiness in 1.4301 (AISI 304).
- Rolling rack included
- 3mm top with 3 mm reinforcement in 1.4301 (AISI 304).
- 6mm ceran glass surface.
- Unit constructed according to DIN 18860_2 with 20 mm drop nose top.
- Also available with 400V / 3ph / 50/60 Hz.

Sustainability



- This model is compliant with Swiss Energy Efficiency Ordinance (730.02).

Optional Accessories

- S04 Glasses & Hard Surfaces Cleaner, 6 x 750ml bottles PNC 0S2884
- Scraper for cook tops PNC 910601
- Portioning shelf 1000x65mm - Marine USPHS (only M2M) PNC 913713

APPROVAL: _____



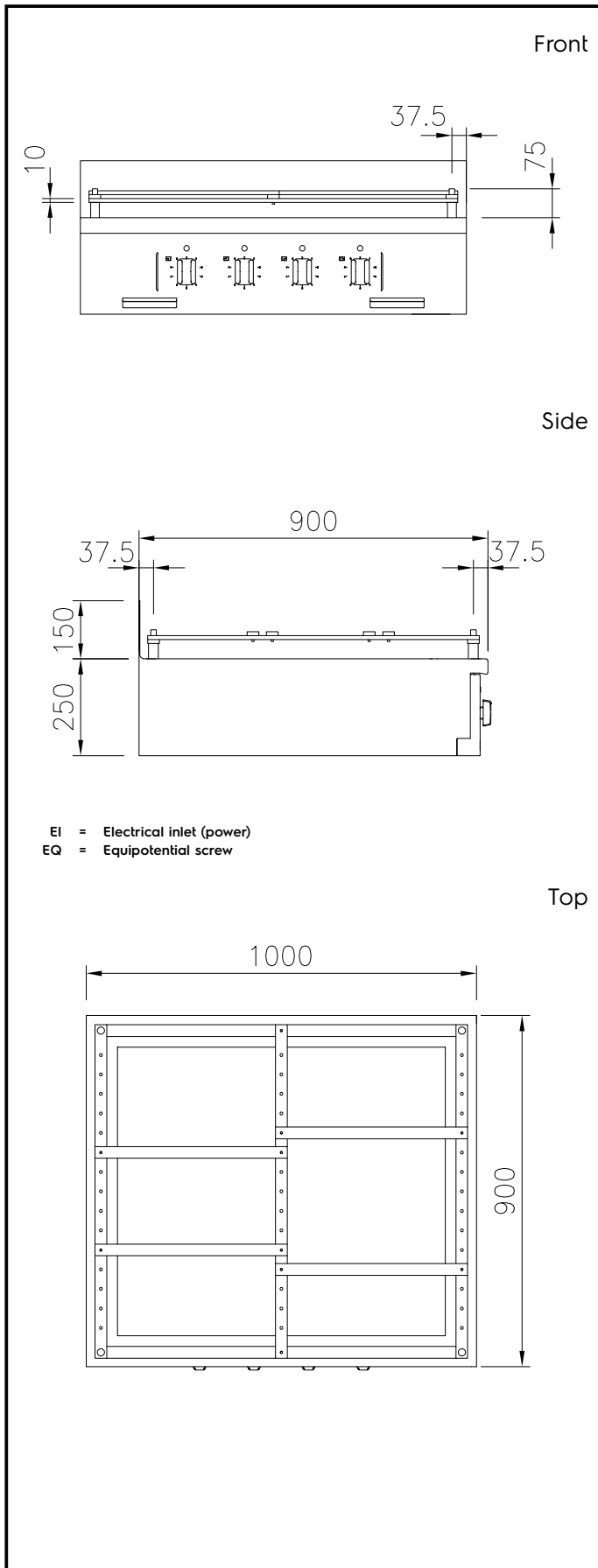

Electric

Supply voltage:	440 V/3 ph/60 Hz
Total Watts:	20 kW

Key Information:

External dimensions, Width:	1000 mm
External dimensions, Depth:	900 mm
External dimensions, Height:	250 mm
Net weight:	100 kg
Configuration:	One-Side Operated;Top
Front Plates Power:	5 - 5 kW
Back Plates Power:	5 - 5 kW
Front Plates dimensions:	340x370 340x370
Back Plates dimensions:	340x370 340x370
Induction Top Dimensions (width):	1000 mm
Induction Top Dimensions (depth):	900 mm

Sustainability

Current consumption:	27.3 Amps
----------------------	-----------